

# TELLO

## Mission Pad User Guide

V1.0 2018.11

**RYZE**

# Introduction

The Mission Pad is used with the Tello EDU when using the Tello SDK 2.0 for programming. The Tello EDU uses its camera to detect the Mission Pad ID and executes commands.

There are 4 double-sided Mission Pads in the Tello EDU package, with each side containing a unique pattern made up of planets, a rocket, and an ID.

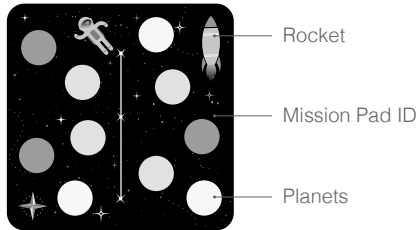

Rocket indicates the forward direction of the X axis.

The ID is a number between 1 and 8 that is printed on each side of the Mission Pad.

Planets display different patterns indicating the ID and coordinates, which the Tello EDU can recognize.

## Coordinates Descriptions

The pattern of each Mission Pad indicates a 3D coordinate. The origin is at the center of the Mission Pad and the plane of the pad represent the X and Y axis. Each Mission Pad has unique coordinates, so the Tello can distinguish between pads.

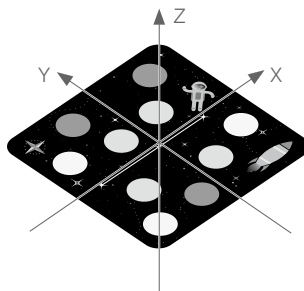

# Operation

In order to work, the Mission Pad requires a Tello EDU with SDK 2.0

1. Place the Mission Pad on a flat surface and adjust the direction of the rocket as desired.
2. Enable mission pad detection on the Tello EDU by using the "mon" command. Place the aircraft in the center of the Mission Pad and use the "mdirection x" command to enable forward or downward camera detection.

3. Use the “takeoff” command to takeoff the Tello EDU and hover in place. Use a command with “mid” to recognize and fly to a Mission Pad.

## Command Descriptions

Command	Descriptions	Response
mon	Enable mission pad detection (both forward and downward detection are enabled).	
moff	Disable mission pad detection.	
mdirection x	<p>“x” = 0/1/2</p> <p>0 = Enable downward detection only            1 = Enable forward detection only            2 = Enable both forward and downward detection</p> <p>Notes:            Perform “mon” command before performing this command.            The detection frequency is 20 Hz if only the forward or downward detection is enabled. If both the forward and downward detection are enabled, the detection frequency is 10 Hz.</p>	
go x y z speed mid	<p>Fly to the “x”, “y”, and “z” coordinates of the Mission Pad</p> <p>“mid” = m1-m8            “x” = -500-500            “y” = -500-500            “z” = -500-500            “speed” = 10-100 (cm/s)</p> <p>Note: “x”, “y”, and “z” values can’t be set between -20 – 20 simultaneously.</p>	ok / error
curve x1 y1 z1 x2 y2 z2 speed mid	<p>Fly at a curve according to the two given coordinates of the Mission Pad ID at “speed” (cm/s).</p> <p>If the arc radius is not within a range of 0.5-10 meters, it will respond with an error.</p> <p>“x1”, “x2” = -500-500            “y1”, “y2” = -500-500            “z1”, “z2” = -500-500            “speed” = 10-60</p> <p>Note: “x”, “y”, and “z” values can’t be set between -20 – 20 simultaneously.</p>	

<p>jump x y z speed yaw mid1 mid2</p>	<p>Fly to coordinates “x”, “y”, and “z” of Mission Pad 1 after recognizing, and recognize coordinates 0, 0, “z” of Mission Pad 2 and rotate to the yaw value after hovering at the coordinates.</p> <p>“mid” = m1-m8 “x” = -500-500 “y” = -500-500 “z” = -500-500 “speed” = 10-100 (cm/s)</p> <p>Note: “x”, “y”, and “z” values can’t be set between -20 – 20 simultaneously.</p>	<p>ok / error</p>
---	---	-------------------

mid = the Mission Pad ID.

m1 to m8 = the range of Mission Pad IDs.

m-1 = the Tello EDU randomly selects a Mission Pad.

m-2 = the Tello EDU selects the nearest Mission Pad that is detected.

**Example: go 100 100 100 60 m1**

After enabling mission pad detection, the Tello EDU detects the Mission Pad marked 1. If the Mission Pad is recognized successfully, the aircraft flies at a speed of 60 cm/s to the coordinates (100, 100, 100). If the Mission Pad is not recognized, the aircraft hovers in place and an “error” message is received on the PC, Mac, or mobile device.

**Example: curve 100 100 100 500 500 500 40 m2**

After enabling mission pad detection, the Tello EDU detects the Mission Pad marked 2. If the Mission Pad is recognized successfully, the aircraft flies at a speed of 40 cm/s in a curve to the coordinates (100, 100, 100) and then to the second coordinates (500, 500, 500). If the Mission Pad is not recognized, the aircraft hovers in place and an “error” message is received on the PC, Mac, or mobile device.

The curve is determined by three points. In this example they are the aircraft’s current position, the first coordinates (100, 100, 100), and the second coordinates (500, 500, 500). If those three points are on a straight line or they do not create a circle with a radius within 0.5 m to 10 m, then the aircraft hovers in place and an “error” message is received on the PC, Mac, or mobile device.

**Example: jump 100 100 100 40 100 m1 m2**

After enabling mission pad detection, the Tello EDU detects the Mission Pad marked 1. If the Mission Pad is recognized successfully, the aircraft flies at a speed of 40 cm/s to the coordinates (100, 100, 100) and hovers in place. Next, the Tello EDU detects the Mission Pad marked 2 and rotates 100°. If either of the pads are not recognized, the aircraft hovers in place and an “error” message is received on the PC, Mac, or mobile device.

# Detection Range

Height: 0.3 - 1.2 m

Range (height of 0.3 m): 0.4×0.4 m

Range (height of 1.2 m): 1×1 m

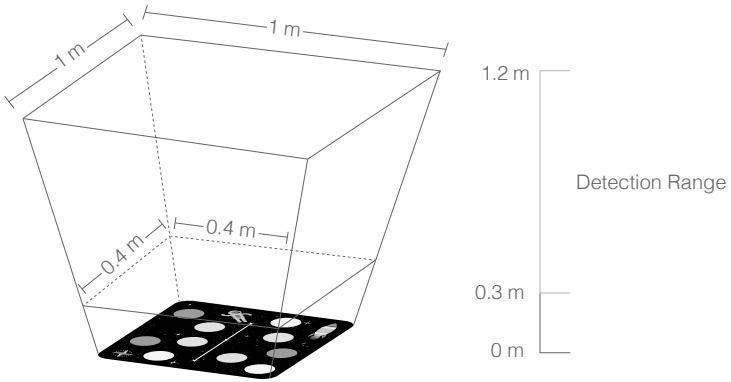

- The Tello EDU cannot detect a Mission Pad outside of the detection range and mid commands cannot be executed during this time.
  - It is recommended to place the Mission Pad on a flat surface with clear patterns. Tello EDU may fail to recognize a Mission Pad that is placed on a surface that is pure black or pure white.
  - Ensure the environment light is sufficient. If it too bright or too dark, it will affect the Tello EDU ability to recognize a Mission Pad.
  - Tello EDU cannot execute mid commands if only forward camera detection is enabled.
-

Ryze Tech Support

<http://www.ryzerobotics.com/support>

This content is subject to change.

**Download the latest version from**  
<http://www.ryzerobotics.com>

Copyright © 2018 Ryze Tech. All Rights Reserved.