

**INSTALL TIME: 30 minutes**

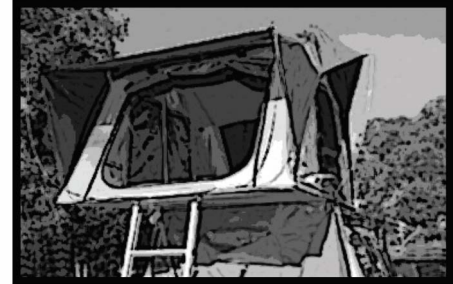

## **1** GET ORGANIZED

*you will need:*

- Your Tent
- The Ladder (in a separate box)
- A Power Drill w/ Phillips screw bit
- A solid, scratch free surface large enough to hold the tent.

(you can use the cardboard that the tent shipped in , or a blanket or furnie pad on the ground)

- A 10mm wrench/socket
- A 13mm wrench/socket
- A friend for step 4, 6 and 7 (10 minutes)

*if mounting to open over the rear of the vehicle, you will also need:*

- Hack Saw or similar (only needed for mounting the tent to open to the rear)
- A Sharpie or suitable instrument for marking metal
- A measuring tape

**...CONT'D**

### **IMPORTANT WARNING!**

**IT IS CRITICAL THAT ALL FRONT RUNNER RACKS AND ACCESSORIES BE PROPERLY AND SECURELY ATTACHED TO YOUR VEHICLE. IMPROPER ATTACHMENT COULD RESULT IN AN AUTOMOBILE ACCIDENT, AND COULD CAUSE SERIOUS BODILY INJURY OR DEATH TO YOU OR TO OTHERS. YOU ARE RESPONSIBLE FOR SECURING THE RACKS AND ACCESSORIES TO YOUR CAR, CHECKING THE ATTACHMENTS PRIOR TO USE, AND PERIODICALLY INSPECTING THE PRODUCTS FOR ADJUSTMENT, WEAR, AND DAMAGE. THEREFORE, YOU MUST READ AND UNDERSTAND ALL OF THE INSTRUCTIONS AND CAUTIONS SUPPLIED WITH YOUR FRONT RUNNER PRODUCT PRIOR TO INSTALLATION OR USE. IF YOU DO NOT UNDERSTAND ALL OF THE INSTRUCTIONS AND CAUTIONS, OR IF YOU HAVE NO MECHANICAL EXPERIENCE AND ARE NOT THOROUGHLY FAMILIAR WITH THE INSTALLATION PROCEDURES, YOU SHOULD HAVE THE PRODUCT INSTALLED BY A PROFESSIONAL INSTALLER SUCH AS A QUALIFIED GARAGE OR AUTO BODY SHOP.**

# 1

## GET ORGANIZED

## ...CONT'D

**A)** Carefully remove the tent from the box and set it upside down (the 4 holes facing up) on your clean, dry work surface. Open the tent to remove the hardware, fly sheet rods, and mounting channels. Lay out all the parts nearby.

Here's what you're looking at:

- ① Your new Feather-Lite tent, folded over, secured with velcro straps
- ② 2 aluminum mounting channels
- ③ Hardware and fasteners (8 6mmx40 bolts, 8 6mm nuts, 8 washers, 8 8mm bolts, 8 slide plate washers, 4 mounting channel end caps, 4 self drilling sheet metal screws.)
- ④ The PVC zip cover
- ⑤ The ladder hinges and 2 bolts/nuts
- ⑥ Ladder
- ⑦ OPTIONAL Front Runner Slimline Rack Tent Mount Kit. (purchased separately)

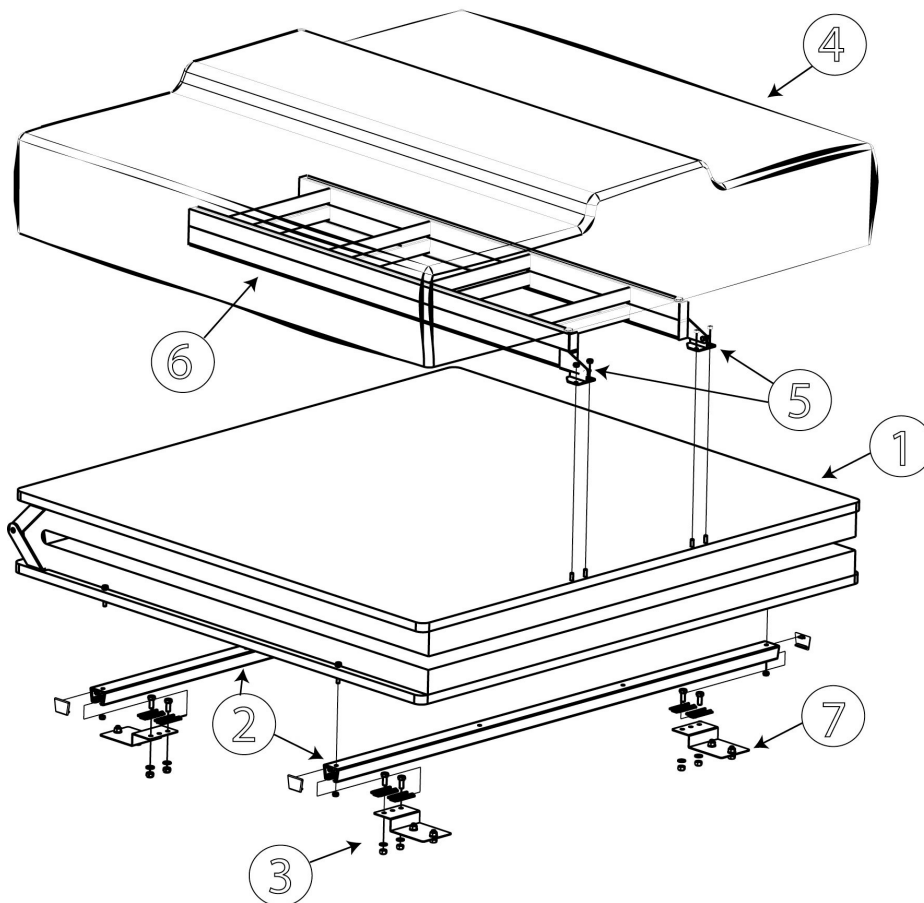
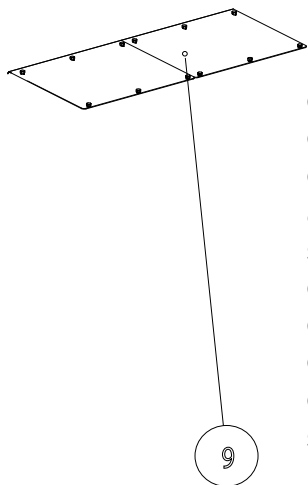

## **B) HOW WILL YOU BE MOUNTING YOUR TENT TO YOUR VEHICLE?**

If you have a roof rack that is a basket with raised edges that rise 2 " or higher than the floor of the rack, it is likely that you won't be able to use that rack to mount your tent without some major modifications.

If you're using the Front Runner Slimline Roof Rack or Load Bars, make sure you have the **Tent Mount Kit** (TBMK001) or **Tent Mount Kit - TALL** (TBMK004).

The roof tent is supplied with sufficient brackets and hardware to allow mounting to roof bars/load bars that are up to 2" wide x 1.25" high.

## **2 MAKE A CHOICE**

Sometimes in life you have to ask yourself the difficult questions. Now is one of those times.

**WHICH WAY DO YOU WANT YOUR TENT TO OPEN?** Over the side of the vehicle, with the ladder supporting the tent on the side of the vehicle? Or over the rear of the vehicle, with the ladder supporting the tent behind the vehicle?

Since your Feather-Lite roof top tent is delivered to you with the option to be mounted to open out over the rear or to open over either side, you will need to decide which direction suits your vehicle and your preference.

### **CONSIDER THIS:**

How will you be accessing the inside of the vehicle when camping?

Will you be using the optional Annex?

On some vehicles it's not physically possible to open out over the rear. Some rear hatch doors and windows open taller than the roof line and may interfere with the tent if it is oriented to open out over the rear of the vehicle.

If the tent opens over the rear there will be a shelter from the sun and rain covering the back area where you access the most cargo. This is especially nice if you use your tailgate as a kitchen, or with the optional annex as a changing room for easy access to luggage.

If you open over the side you still may be able to position the shelter of the tent and/or the annex to cover a side door. This too is handy to access luggage for changing or supplies for food prep. Your tent can open either over the driver's side or passenger side.

If you'd like to position your roof tent on the rack towards the front of the vehicle (because you'd like to use the back of the rack for other gear), the tent will need to open over the sides. *While it is possible to have the tent open over the hood of the vehicle, the ladder will need to be modified to attach either to bull bars or the hood of the vehicle.*

The lowest wind resistance when driving is achieved with the roof tent opening out over the rear of the vehicle. This is because the ladder is stored on top of the tent front to rear.

If you choose to install the tent to open over the rear of the vehicle there is an extra step in the installation procedure -- you will need to shorten the aluminum extrusions by cutting them with a hack saw.

### **DECIDE NOW!**

If your tent is going to open out over the side, SKIP STEP 3!!!

## HINT

For the majority of roof racks and load bars, the aluminum channels will face front to back on the vehicle, parallel with the sides of your vehicle. So -- if you face the tent opening off the rear, the tips of the channels will face the opening and if your tent opens off the side, the opening of the tent will run parallel with the aluminum channels.

Here's how to tell which way your tent opens when it's all folded up --

The nylon and velcro latches are on the sides of the tent.

Look for the 4 holes pre-drilled on one side of the tent floor. This is where the extrusions will attach that mount to your rack or load bars. This is the bottom of the tent.

With the 4 holes facing the ground, the top/opening will fold up and away from the velcro straps. There are 2 pairs of pre-drilled holes along the extrusion on the edge of the tent. This is where the ladder will mount. That is the opening of the tent.

**3\***

**CUT THE CHANNELS?? \* SKIP THIS STEP if you are mounting the tent to open off of the side of your vehicle!**

**A)** If mounting the channels front to rear so the tent will open over the back of the vehicle, you will need to cut the channels to fit the base of the tent.

**WARNING!** - You do not have to cut the aluminum extrusions if you are mounting the tent to open up over the side of your vehicle! The tracks are pre-cut to work as is!!

**B)** Measure 35mm/1.37" from each end of EACH CHANNEL. Mark a straight line with the sharpie.

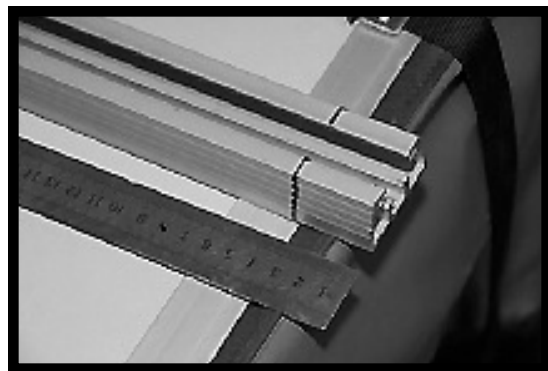
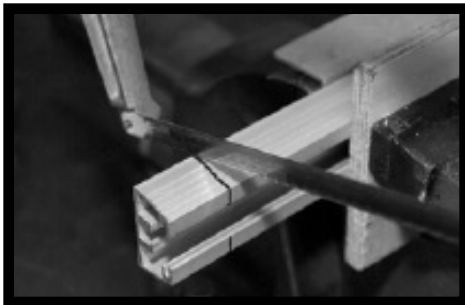

**C)** Cut all 4 ends! Use a hack saw or other tool of choice for cutting through aluminum.

# 4

## INSTALL CHANNELS

**A)** Now that you know which way you want your tent to open, it's time to attach the channels to the tent base.

The channels will run front to back on the tent floor if your tent will be opening over the back of the vehicle. The channels will run side to side on the tent floor if your tent is opening over the side of the vehicle.

The roof tent base is pre-drilled with 4 holes which align with holes in the channels.

Insert the 6 x 40mm bolts through the washers and push them through the 4 holes from the **INSIDE** of the tent.

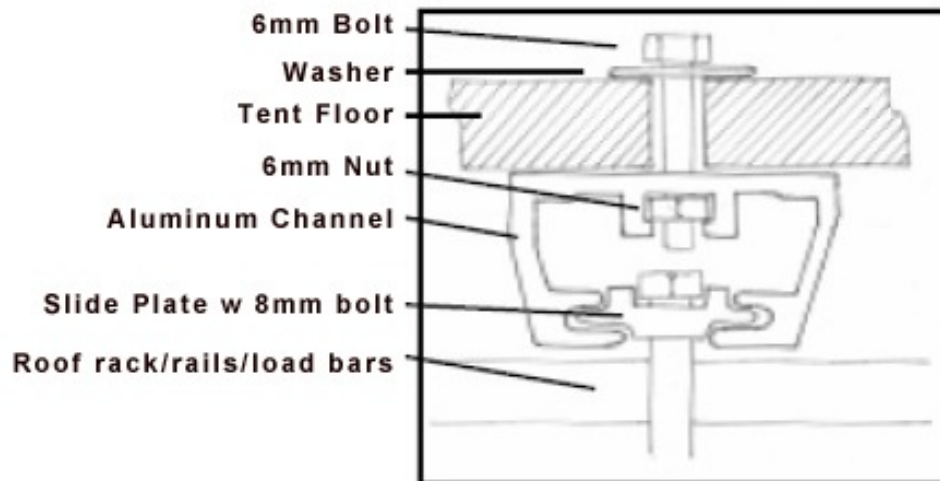

**B)** Slide 2 6mm nuts into each channel.

Line up the channels in the direction determined by your tent orientation. Insert bolts into nuts and tighten.

You will have to open the tent and reach deep into the tent to access the heads of the back bolts. You may need a hand for this step, as the nut in the channel and bolt must line up.

•FYI• The bolt heads will protrude slightly from the floor of the tent, but you'll never notice since they will be under the mattress.

**C)** Use a power drill to set the self-drilling screws at each end of the channels – these must screw into the aluminum outer edge section.

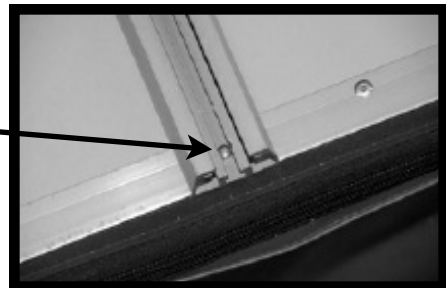

# 5

## INSTALL RACK MOUNTING POINTS

**A)** Determine your roof carrier mounting points.

- If you are mounting your tent to an old fashioned steel rack, or oval/rectangular rails and load bars that are no larger than 2" wide x 1.25" high, use the included bracket plates. Insert the included bolts through the 8 slide plates, and insert 4 slide plates per channel.

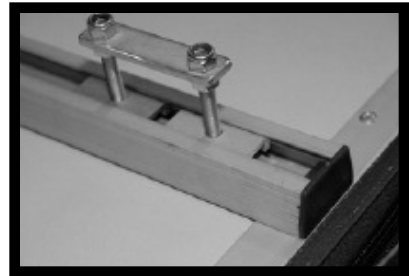

To mount your tent to a Front Runner Slimline series Roof Rack, use the 8mm bolts included with the Front Runner Tent Mount Kit and insert the bolts into all 8 slide plates, then slide 4 plates into each channel. (You can discard the 8mm bolts that came with the tent).

**B)** Fit the plastic end caps on each end of the mounting channels (it may be necessary to use the rubber mallet to tap them into place).

# 6

## INSTALL LADDER AND COVER

**A)** Grab your helper friend and turn your tent over with the channels facing the ground. Be careful with the protruding bolts. You may need to prop up the tent using the channels.

**B)** Line up the hinge plates to the the predrilled holes along the aluminum extrusion. Use the 4 remaining 6 x 40mm bolts to mount the 2 hinge plates. Insert the bolts from inside the tent with the nuts on the outside. Tighten.

**...CONT'D**

**C)** Bolt on ladder, with ladder hinge plate on the inside.

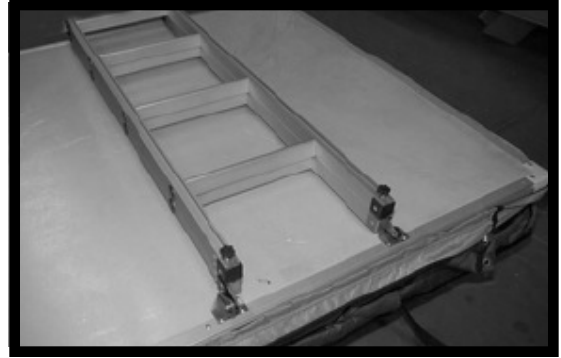

**D) INSTALL VINYL (PVC) COVER**

Slide blue retaining edge into sliding channel of tent base. Pull through until cover lines up with tent. Fold cover over tent and out of the way for placement of tent on the vehicle.

**7 MOUNT TENT ON VEHICLE**

If you're using the Slimline Rack with the FRONT RUNNER SLIMLINE RACK TENT MOUNT KIT, see TENT MOUNT KIT INSTALLATION GUIDE and mount your feet first.

**Grab your helper friend to lift the tent on to your roof mounting system.**

**TIP: Be careful not to scratch the vehicle with the bolts hanging out of the slide plates.**

For all other load bars, rails, racks -- after you set the tent on your roof carrier, slide the plates and adjust the bolts to straddle the rail/bar and tighten the bracket plate until secure.

# 8

## OPEN YOUR TENT AND ADJUST THE LADDER

Set up the tent once, and you'll never have to think about it again!

### A) POP THE TENT

If your PVC cover is on, loosen the black nylon straps and velcro corner tabs and then unzip around 3 edges. The cover can then be folded over and out of the way OR removed completely by sliding it out of the sliding track.

2. Slide the ladder out until the locking pins engage in the holes
3. Use the ladder as a lever to pull down and open the tent. The tent will just pop up into shape.

**WARNING:** The locking pins can be twisted and locked in the open position, so ensure that the pins are unlocked and engaged in the holes. Always make sure that the pins are in the closed position before attempting to climb the ladder!



**B)** Determine the ideal angle for the ladder. You want the entire sleeping platform to be level and straight.

The ladder is pre-drilled to lock into place at the longest safe position.

If you level the platform out and find that the angle of the ladder is too great – you can straighten the ladder as desired and drill 2 new holes for the pins to lock in to. (this may be the case on shorter vehicles)

Loosen the pins and adjust it to the desired angle. Mark the position of the ladder legs and using a 7mm bit, drill the 2 additional holes for the pins to lock in to.



**WARNING! READ ME! NEVER EXTEND THE LADDER BEYOND THE PRE-DRILLED HOLES AND FACTORY LOCKING POSITION. UNDER NO CIRCUMSTANCES SHOULD YOU DRILL NEW HOLES PAST THE CURRENT HOLES. THE LADDER IS NOT SAFE EXTENDED ANY TALLER.** If a longer ladder is needed for extremely tall vehicles, please order a Ladder Extension -- **Part No: TENT022**

**...CONT'D**

**C)** Insert the 6 steel rods to support the fly sheet.

The 2 longer rods are for the windows on each side. The 4 shorter front and rear rods mount into holes in the outer edge. Locate the eyelets in the Flysheet (in the middle of the sides, and on the corners of the front and back).

The two center rods on each side slide into the tongue and groove aluminum extrusion between the floor boards. Practice inserting the rods by using two hands to create a curve and thus making it easier to insert into the slots. The 4 rods for the front and rear fit into the holes near the ends of the aluminum extrusion on the base of the tent. The holes are angled, and once again, you will want to use 2 hands to maneuver the rods into the slot.

Note: The window rods will retain some curve after the first use - no worries! This is normal.

**To close the tent – reverse the above procedures. Store the fly sheet rods in their bag, in the tent underneath the mattress.**

**10 YOU DID IT! Now make your bed.**

You have some room inside the tent to set out your sleeping bag, even your pillows (if they're not overstuffed California King Size!) Or you can tuck fitted sheets around the mattress and throw on a comforter. Toss in your teddy bear and close the tent back up. When you arrive at your destination, pop the tent open and you'll already be set for the best camp sleep of your life!

**11 YOU MADE YOUR BED. NOW SLEEP IN IT.**

**A)** After your first adventure, check the tension on all the bolts and screws and re-tighten where needed. You'll find a small amount of settling has happened.

**B)** Go on many more adventures. Periodically check the bolts - it's always wise to double check your fasteners every once and a while.

## **12** TENT CARE – READ ME!!

Do not over tighten the black nylon retaining straps – these should NOT be used to force the bases together or damage will result. Only apply enough tension to prevent the cover from flapping in transit.

Do not store the tent longer than 2-3 days when wet. Open the tent to dry as soon as possible.

If the tent is to be stored for long periods – open the tent and windows occasionally to allow it to air and make sure it is ALWAYS stored in a dry location.

Do not store directly on a concrete floor as moisture will penetrate the tent.

Do not drag the tent over hard surfaces or damage will result.

Do not drill the ladder locating holes below the existing holes. If a longer ladder is needed for extremely tall vehicles, please order the correct Ladder Extension --  
**Part No: TENT022**

**WARNING! READ ME AGAIN! NEVER EXTEND THE LADDER BEYOND THE PRE-DRILLED HOLES AND FACTORY LOCKING POSITION. UNDER NO CIRCUMSTANCES SHOULD YOU DRILL NEW HOLES PAST THE CURRENT HOLES. THE LADDER IS NOT SAFE EXTENDED BEYOND THIS POINT.**

**THE FINE PRINT:** Now that your Front Runner Feather-Lite Roof Top Tent is installed, please be safe when getting in and out of the tent. Take your time when backing out and make sure you have a firm footing on the ladder.

And always remember- you've raised the height of your vehicle and changed the center of gravity - so use caution when entering parking structures and driving under other low hanging obstacles. Also use caution when taking tight turns - as you have altered your center of gravity because you have added weight to your roof top.

For the safety of the tent system and your vehicle, please obey all traffic laws and adjust speed accordingly to the load being carried and the conditions of the road.

Cargo will affect the vehicles handling.

You'll get many years of enjoyment out of your Front Runner Feather-Lite Roof Top Tent if you use common load carrying sense.

➔ Modifying your vehicle involves some risks and may void certain aspects of your vehicle's warranty.